

Manatrol check valves of series C for pipe mounting provide free flow in one direction and block flow in the counter direction. Depending on material specification, these valves are suited for use in hydraulic and pneumatic systems.

Specific poppets and poppet guides ensure reliable functional integrity even at high flow rates and/or pulsations.

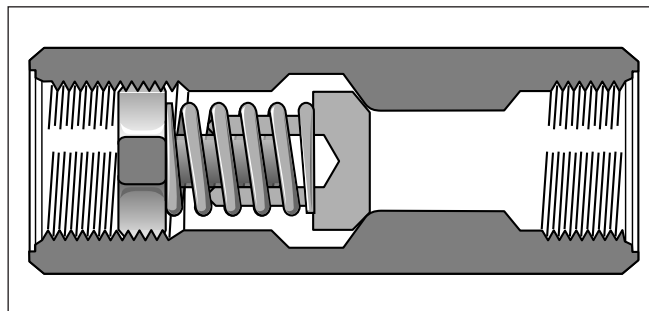
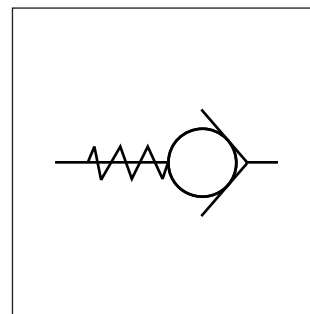

Technical data

Size			200	400	600	800	1200	1600
Max. operating pressure	steel	[bar]	350	350	350	350	350	210
	brass	[bar]	140	140	140	140	140	34
Pressure drop Δp		[bar]	10	10	10	10	1	1
Flow Q		[l/min]	40	65	110	155	112	160

Ordering code

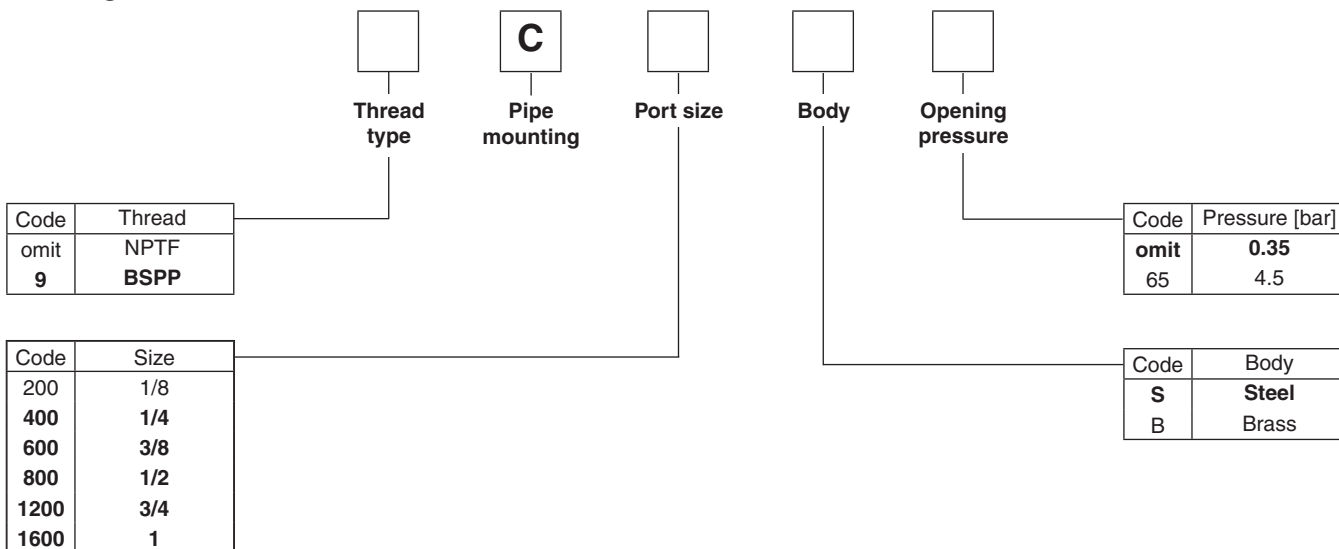

**Bold letters =
Short-term availability**

Δp/Q performance curves

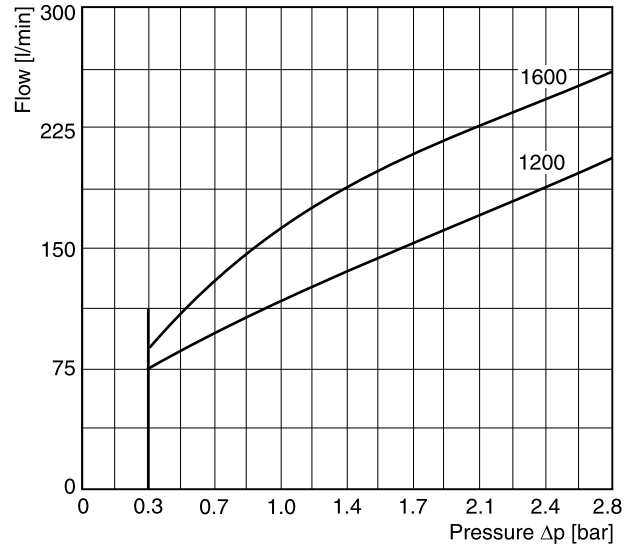
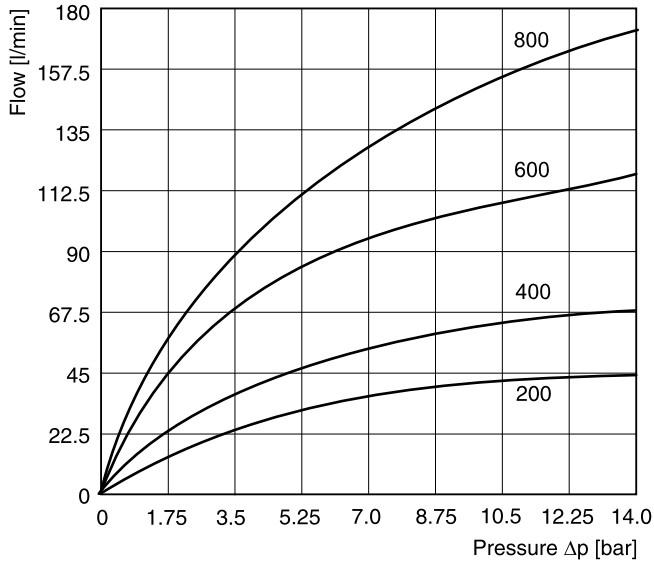

All characteristic curves measured with HLP46 at 50°C.

Dimensions

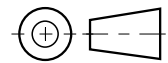
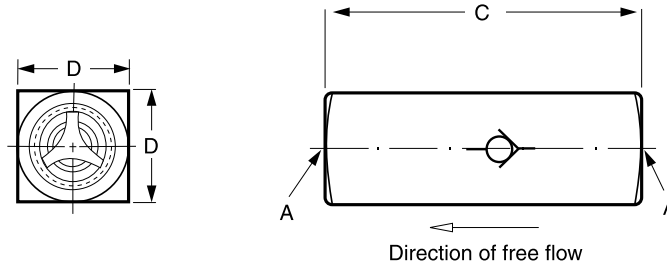

10

Size	Threaded connection R*		Dimensions [mm]		Weight [kg]
	G thread	NPTF thread	B	L	
C 200	R 1/8"	1/8-27 NPTF	16	51	0.05
C 400	R 1/4"	1/4-18 NPTF	21	66	0.2
C 600	R 3/8"	3/8-18 NPTF	25	70	0.2
C 800	R 1/2"	1/2-14 NPTF	32	87	0.6
C 1200	R 3/4"	3/4-14 NPTF	38	99	0.9
C 1600	R 1"	1-11-1/2 NPTF	45	127	1.5

* For alternative thread design, see ordering code.