

Pressure Drop Curves

The recommended level of the initial pressure drop for suction filters is 0.03 bar.

If the medium used has a viscosity different from 32cSt, pressure drop over the filter can be estimated as follows:

$$\Delta p = (\Delta p_{32} \times \text{viscosity of medium used}) / 32\text{cSt}$$

Filter housing and element pressure drop based on 32cSt fluid viscosity and 0.87 density.

ATZ 1-120 (G1^{1/2}) Empty Housing

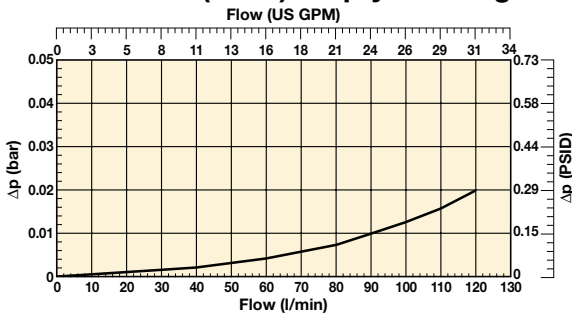

ATZ 300 (2^{1/2} SAE FLANGE) Empty Housing

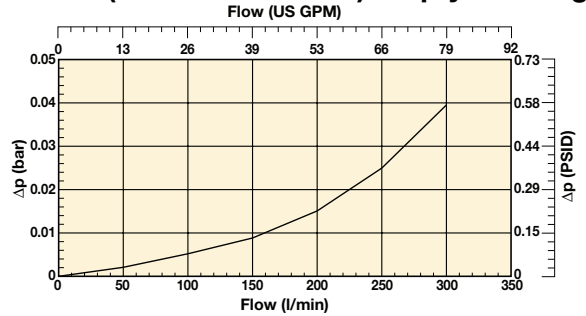

ATZ120 Filter Element Length 1

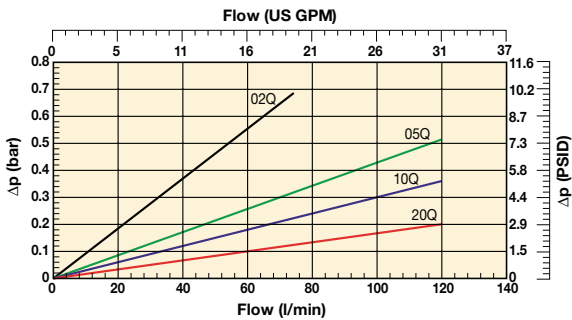

**ATZ300 Filter Element Length 2
(cellulose and stainless steel)**

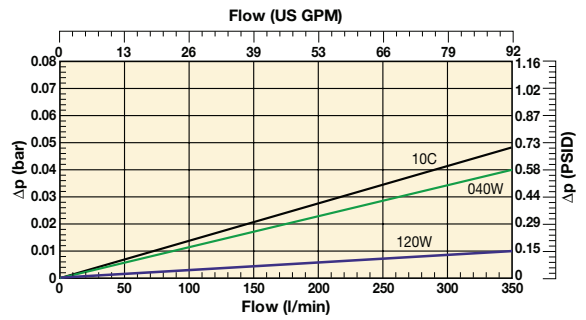

**ATZ120 Filter Element Length 1
(cellulose and stainless steel)**

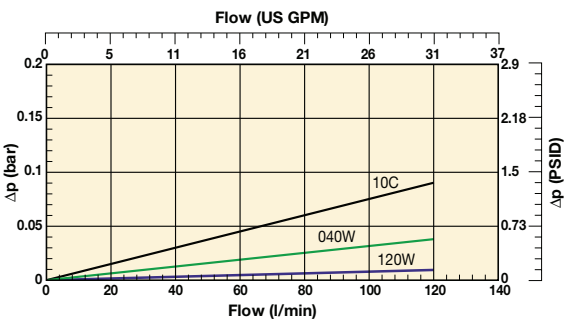

ATZ300 Filter Element Length 2

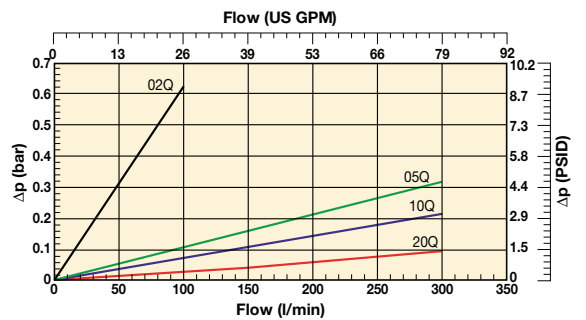

Suction Filters

ATZ Series

Ordering Information

Standard products table

Part number	Supersedes	Flow (l/min)	Model number	Element length	Media rating (µ)	Seals	Indicator	Bypass settings	Ports	Included options	Replacement elements	Supersedes
ATZ110CBP1XG241	ATZ120-G1½ FXX1-R-10 B M	120	ATZ120	Length 1	10 NOM	Nitrile	Plugged	Blocked	G1½"	None	937958	FXX1-R-10
ATZ110QBP1XG241	ATZ120-G1½ FXW1-R-10 B M	120	ATZ120	Length 1	10 ABS	Nitrile	Plugged	Blocked	G1½"	None	937964Q	FXW1-R-10
ATZ210CBP1XR481	ATZ300-S2½-C FXX3-10 B M	300	ATZ300	Length 2	10 NOM	Nitrile	Plugged	Blocked	2½" SAE-3000 PSI	None	937959	FXX3-10
ATZ210QBP1XR481	ATZ300-S2½-C FXW3-10 B M	300	ATZ300	Length 2	10 ABS	Nitrile	Plugged	Blocked	2½" SAE-3000 PSI	None	937965Q	FXW3-10

Note: Filter assemblies ordered from the product configurator below are on extended lead times. Where possible, please make your selection from the table above.

Product configurator

Configurator example ATZ filter

Box 1	Box 2	Box 3	Box 4	Box 5	Box 6	Box 7	Box 8
ATZ	2	10C	B	U2	X	R48	1

Box 1	Box 2	Box 3							
Code	Filter type	Degree of filtration							
ATZ	Housing	Code	Element media			Glass fibre			
	ATZ 1-120	1	Microglass III (for disposable elements)			Wire mesh			
	ATZ 2-300	2							
			Cellulose		Abs. rating				
			Nom. rating						
			Disposable element	10C	02Q	05Q	10Q	20Q	040W

Box 4	Seal type	
	Seal material	Code
	Nitrile	B
	Fluoroelastomer	V
	Neoprene	N

Box 5	Indicator	
		Code
	Vacuum gauge, setting -0.15 bar, M10x1	U1
	Vacuum gauge, setting -0.3 bar, M10x1	U2
	Vacuum switch 42V, -0.15 bar setting, NO/NC, M10 x 1	V1
	Vacuum switch 42V, -0.30 bar setting, NO/NC, M10 x 1	V2
	Vacuum switch 250 VAC, -0.15 bar setting, NO/NC, M10 x 1	V3
	Vacuum switch 250 VAC, -0.30 bar setting, NO/NC, M10 x 1	V4
	No indicator, indicator ports not machined	N
	No indicator, indicator port plugged	P
	Other settings for indicators / gauges on request	on request

Box 6	Bypass valve	
	Bypass valve	Code
	Blocked bypass	X

Box 7	Filter connection	
	Ports	Code
	G1½" + 2 x G1" (For ATZ 1-120 only)	G24
	2½" SAE-3000 PSI + 2 x G1½" (For ATZ 2-300 only)	R48

Box 8	Options	
	Options for ATZ 1-120	Code
	1 x G1½" + 1 x G1" plugged	1
	Not plugged	Q
	1 x G1" right plugged	R
	2 x G1" left & right plugged	P
	Special	on request
	Options for ATZ 2-300	
	1 x SAE16 plugged	1
	Not plugged	Q
	Special	on request

Highlights Key (Denotes part number availability)

123	Item is standard
123	Item is standard green option
123	Item is semi standard
123	Item is non standard

Note: Standard items are in stock, semi standard items are available within four weeks

Degree of filtration						Media code
Average filtration beta ratio β (ISO 16889) / particle size µm [c]						
βx(c)=2	βx(c)=10	βx(c)=75	βx(c)=100	βx(c)=200	βx(c)=1000	
% efficiency, based on the above beta ratio (βx)						
50.0%	90.0%	98.7%	99.0%	99.5%	99.9%	02Q
N/A	N/A	N/A	N/A	N/A	4.5	05Q
N/A	N/A	4.5	5	6	7	10Q
N/A	6	8.5	9	10	12	20Q
6	11	17	18	20	22	

Spare element table						
ATZ 1-120	FXX1-R-10	FXW1-R-2	FXW1-R-5	FXW1-R-10	FXW1-R-20	SF1-R-40
Part number spare element	937958	937960Q	937962Q	937964Q	937966Q	937967
ATZ 2-300	FXX3-10	FXW3-2	FXW3-5	FXW3-10	FXW3-20	SF3-40
Part number spare element	937959	937961Q	937963Q	937965Q	937966Q	937968

Visual indicator	
Setting	-0.3 bar
Thread connection	M10x1
Code	FMUV2VBMM10L

Electrical switch	
Setting	-0.3 bar
Thread connection	M10x1
Switch type	NO or NC
Elec.connection	AMP terminal 6.3x0.8
Protection	IP54 (terminal IP00)
Performance	125-250 VAC (Li 0,5A, Lr 2,0A max)
	12-28 Vdc (Li 1,0A, Lr3,0A max)
Code	FMUU2VBMM10L

Note 1: Part numbers featured with bold highlighted codes will ensure a 'standard' product selection.

Note 2: Alternate displayed part number selection will require you to contact Parker Filtration for availability.



Medium Pressure Filters

15/40/80CN Series

MAX 600 l/min - 70 bar



Medium Pressure Filters

15/40/80CN Series

Features & Benefits

Features	Advantages	Benefits
56 bar fatigue rating (eight times that of a spin-on)	Ability to provide reliable service under tough cyclic operating conditions	Reduced downtime due to premature filter failures
	Can be utilised in applications where high pressure filters may have been only option	Reduced costs, better "fit" for the application
Diametral (side) seal between head and bowl	Proven reliability in cyclic applications	No downtime, no leaks
	Reduced importance of bowl torque	Performs with "real world" service
Dust seal	Prevents contamination from building up on bowl/head threads	Easier service, eliminates thread galling
40CN-2 meets automotive HF3 standard	Automotive industry acceptance	Satisfies specifications without need for further testing and/or approval
15CN meets automotive HF2 standard		
Cast aluminium head	Low profile, lightweight and durable	Less weight, smaller envelop and cleaner appearance
Reinforced Microglass III replacement elements	Multi-layered design produced high capacity and efficiency	Great performance value
	Wire support reduces pleat bunching, keeps performance consistent	Reliable performance throughout element life Reduces downtime, maximises element life
Complete performance data disclosure	All pertinent information is provided in an easy-to-compare format	No hidden deficiencies
		Easy selection of proper filtration
Visual, electrical or electronic indicators available	Check element condition at a glance	Optimise element life, prevent bypassing
	Right style for the application	Matches your system electrical connections
Coreless Ecoglass III replacement elements	No metal content in element	Environmentally friendly disposal by incineration
	Reduced overall weight of 50%	Lower element replacement costs
	Easy compaction of used elements	Lower disposal cost
	Conversion kits available: new bowl with permanent core	Retrofit coreless design to housings already installed

Typical Applications

- Compressor lube oil
- Off-line filter loops
- Machine tools (Automotive standard)
- Hydrostatic drive charge pumps
- Mobile equipment
- Pilot lines for servo controls
- Oil patch drilling equipment
- Injection moulding

The Parker Filtration 15/40/80CN Series Medium Pressure Filters.

This partial list of applications for Parker "CN" Series Filters has a common factor, the need for an economical, medium pressure range filter with excellent fatigue pressure ratings. Prior to the availability of the "CN" filter, applications such as those listed were restricted by limitations of a spin-on can, or forced into the higher-cost range of high pressure filters.

The "CN" Series fills this gap and is now available with environmentally friendly Ecoglass III elements.



Specification

Pressure ratings:

Maximum allowable operating pressure: 70 bar
 Rated fatigue pressure: 56 bar

Connections:

Several threaded port options available, flange faced ports available on 80CN.

Connection style	Model	40CN	80CN
BSPF(G)	15CN	1 1/4", 1 1/2"	1 1/2", 2"
SAE	12, 16	16, 24	24, 32
ISO 6149	M27	M33	M42, M48
Metric 3000-M			2"

Filter housing:

Head material aluminium.
 Bowl material hard anodized aluminium.

Seal material:

Nitrile or fluoroelastomer.

Operating temperature range:

-20°C to +100°C.

Bypass valve & indicator settings:

Table following gives bypass valve and corresponding indicator setting.

Bypass	Indicator
1.7 bar	1.2 bar
3.5 bar	2.5 bar

Filter element:

Degree of filtration:

Determined by Multipass-test according to ISO 16889.

Flow fatigue characteristics:

Filter media is supported so that the optimal fatigue life is achieved (ISO 3724).

Microglass III (available by request)

Supported with epoxy coated metal wire mesh, end cap material reinforced composite and metal inner core.
 Collapse rating 20 bar (ISO 2941).

Ecoglass III

Supported with plastic net, end cap material reinforced composite. No metal parts. Collapse rating 10 bar (ISO 2941).
 Filter element can only be used together with bowl including Eco-adaptor.
 Note: Ecoglass III contributes to ISO 14001 quality.

Indicator options:

- visual M3.
- electrical T1.
- electronic F1 (PNP).
- electronic F2 (NPN).

For indicator details see catalogue section 6.

Weights (kg):

Model	Length 1	Length 2
15CN	1.1	1.6
40CN	2.0	2.5
80CN	5.6	6.9

Fluid compatibility:

Suitable for use with mineral and vegetable oils, and some synthetic oils. For other fluids, please consult Parker Filtration.

15CN

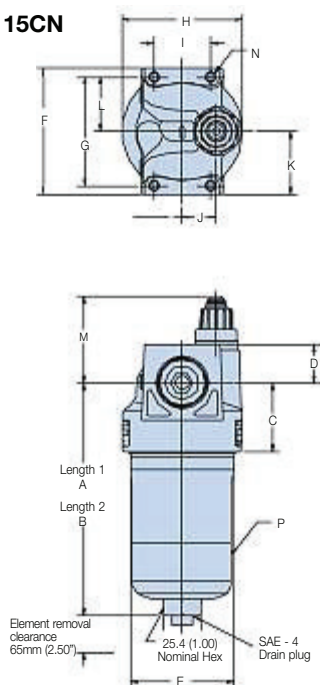

40CN

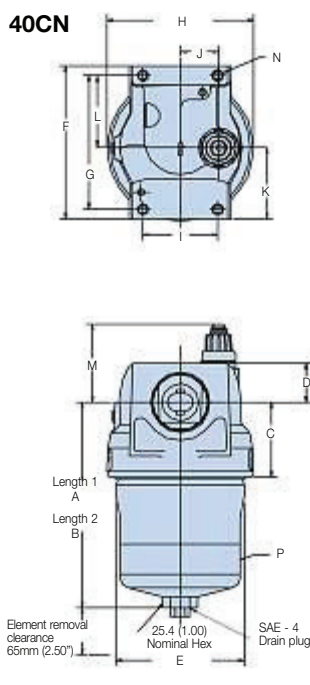

80CN

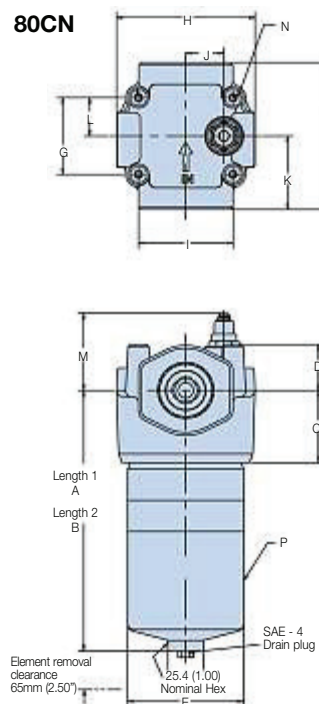

Dimensions in mm (inch)

Model	A	B	C	D	E	F	G	H	I	J	K	L	M*	N	P
15CN	156.6 (6.17)	250.7 (9.87)	46.5 (1.83)	25.4 (1.09)	71.1 (2.80)	85.9 (3.38)	73.2 (2.88)	82.6 (3.25)	38.1 (1.50)	22.9 (0.90)	42.9 (1.69)	36.6 (1.44)	53	4xM6-1.0x7.9 deep	20-27 Nm
40CN	170.8 (6.73)	262.4 (10.33)	62.0 (2.44)	32.6 (1.28)	107.2 (4.22)	127.0 (5.00)	111.0 (4.37)	121.9 (4.80)	62.0 (2.44)	31.8 (1.25)	58.8 (2.32)	60.2 (2.37)	53	4xM8-1.25x13 deep	57-68 Nm
80CN	280.9 (11.06)	401.6 (15.81)	77.7 (3.06)	49.5 (1.95)	124.8 (4.91)	158.7 (6.25)	82.6 (3.25)	151.4 (5.96)	101.6 (4.00)	41.1 (1.62)	79.4 (3.12)	41.3 (1.63)	69	4xM8-1.25x16 deep	80-95 Nm

Note: add 45mm for T and F indicators

Medium Pressure Filters

15/40/80CN Series

80CN Flange Face Details (SAE 2" 3000-M)

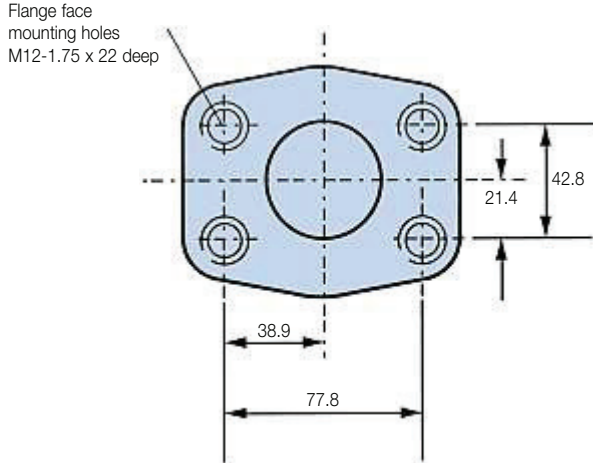

Pressure Drop Curves

With 1.7 bar bypass the recommended initial pressure drop is max 0.5 bar.
 With 3.5 bar bypass the recommended initial pressure drop is max 1.0 bar.
 If the medium used has a viscosity different from 30 cSt, pressure drop over the filter can be estimated as follows:
 The total $\Delta p = \Delta p_{ph} + (\text{element } \Delta p_e \times \text{working viscosity}/30)$.

15CN-1 Elements

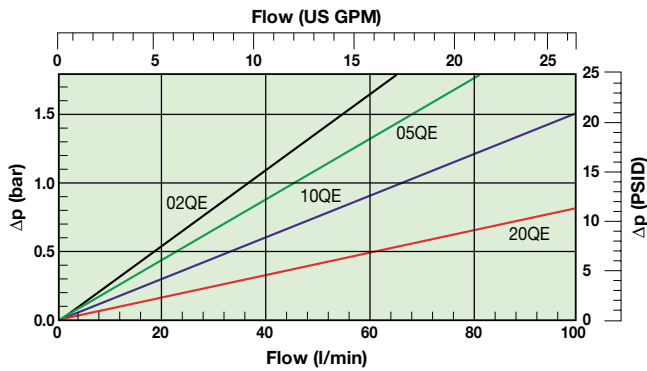

15CN Empty Housing

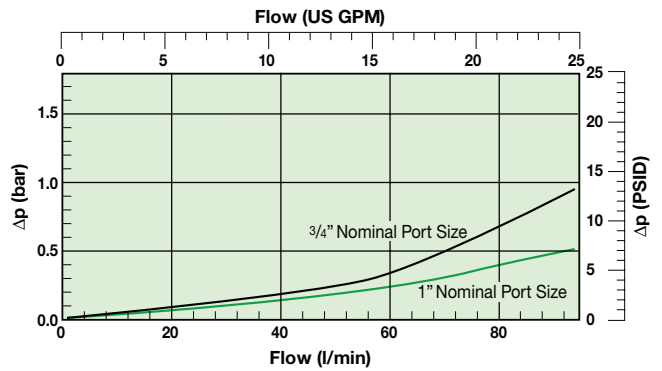

15CN-2 Elements

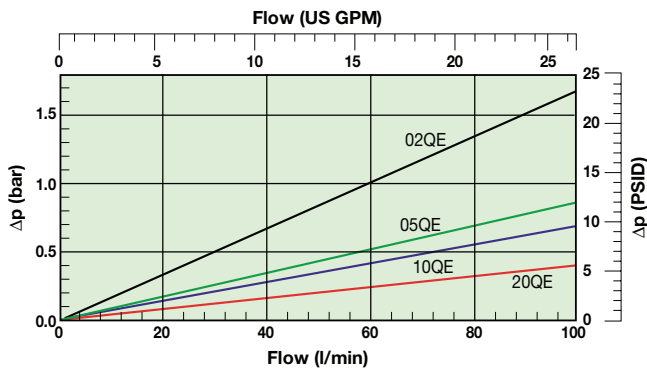

Pressure Drop Curves

40CN-1 Elements

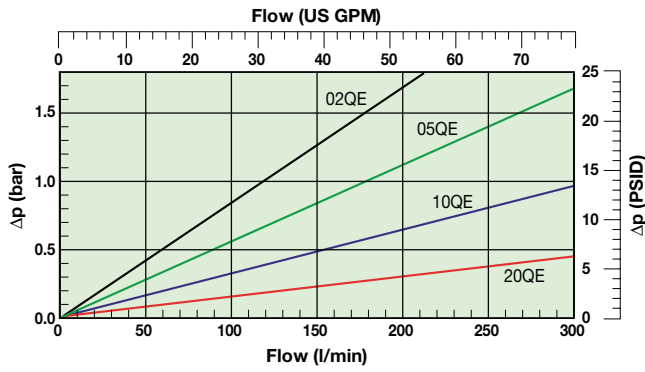

40CN Empty Housing

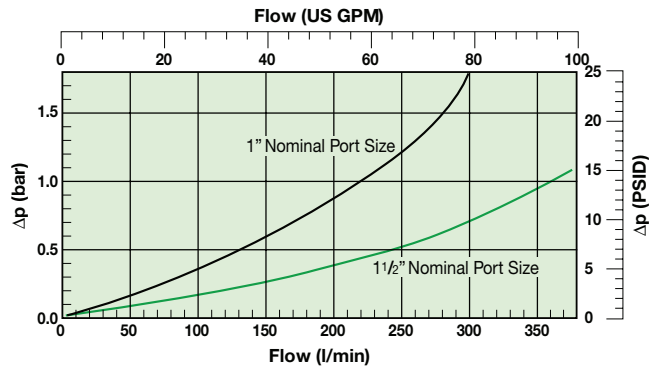

40CN-2 Elements

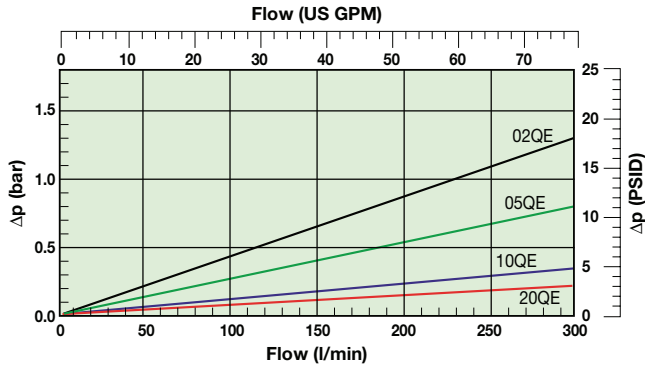

80CN-1 Elements

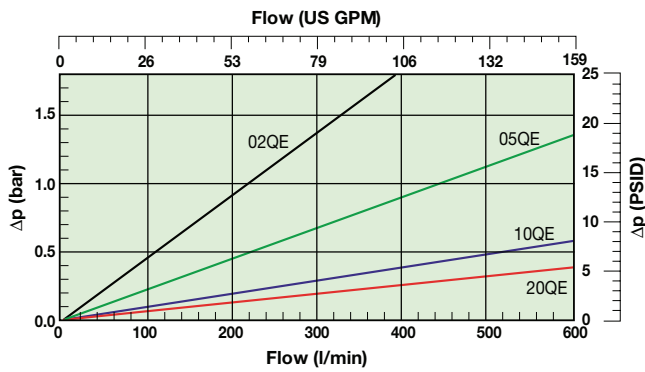

80CN Empty Housing

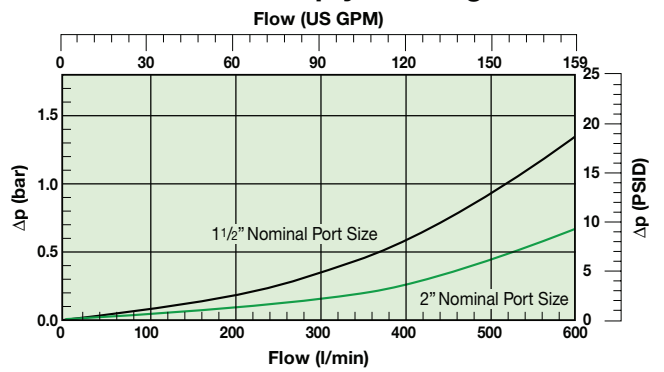

80CN-2 Elements

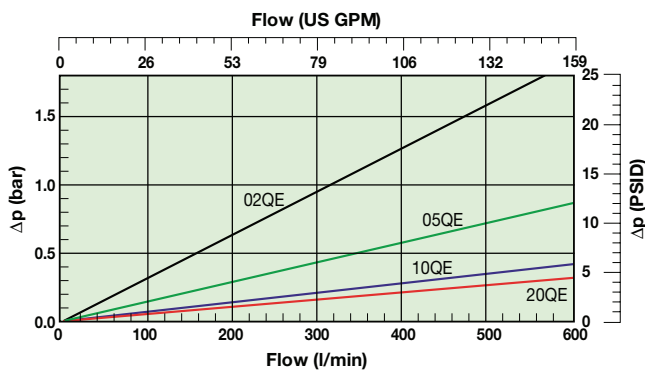

15/40/80CN Series

Element Service

- A. Stop the system's power unit.
- B. Relieve any system pressure in the filter line.
- C. Drain the filter bowl if drain port option is provided.
- D. Loosen and remove bowl.
- E. Remove element by pulling downward with a slight twisting motion and discard.
- F. Check bowl o-ring and anti-extrusion ring for damage and replace if necessary.
- G. Lubricate element o-ring with system fluid and place on post in filter head.
- H. Install bowl by rotating counter clockwise and tighten to specified torque.
 - 15CN – 20-27 Nm (15-20ft. lbs)
 - 40CN – 57-68 Nm (42-50ft. lbs)
 - 80CN – 80-95 Nm (60-70ft. lbs)
- I. Confirm there are no leaks after powering the system.

CN Filters Parts List

Index	Description
1	Head
2	Indicators M3-visual auto reset: 1.2 bar M3-visual auto reset: 2.5 bar
3	T1-electrical: 1.2 bar c/w DIN 43650 connector T1-electrical: 2.5 bar c/w DIN 43650 connector F1-electronic PNP with 4 LEDs: 1.2 bar F1-electronic PNP with 4 LEDs: 2.5 bar F2-electronic NPN with 4 LEDs: 1.2 bar F2-electronic NPN with 4 LEDs: 2.5 bar
4	Bypass valve 1.7 bar assembly 3.5 bar assembly
5	Element (see replacement element part numbers)
6	Bowl Single length with drain Single length with reusable core and drain Single length without drain Double length with drain Double length with reusable core and drain Double length without drain
7	Bowl and dust seal Nitrile Fluoroelastomer
8	Drain plug: SAE-4 Nitrile Fluoroelastomer

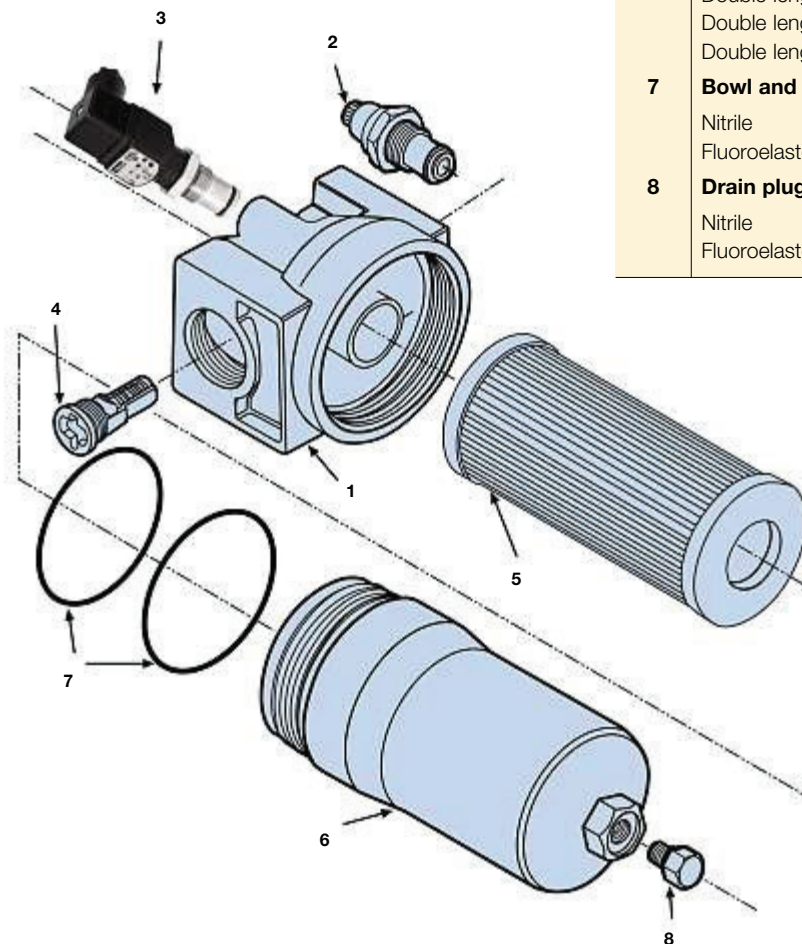

Ordering Information

Standard products table

Part numbers	Supersedes	Flow (l/min)	Model number	Element length	Media rating (µ)	Seals	Indicator	Bypass settings	Ports	Replacement elements
15CN110QEVT1KG164	F315CN1R10QETW350C2C219	50	15CN	Length 1	10	Fluoroelastomer	Electrical	3.5 bar	G1"	936700Q
15CN110QEV3M3KG164	F315CN1R10QEM250C2C219	50	15CN	Length 1	10	Fluoroelastomer	Visual	3.5 bar	G1"	936700Q
15CN120QEVT1KG164	F315CN1R20QETW350C2C219	80	15CN	Length 1	20	Fluoroelastomer	Electrical	3.5 bar	G1"	936701Q
15CN120QEV3M3KG164	F315CN1R20QEM250C2C219	80	15CN	Length 1	20	Fluoroelastomer	Visual	3.5 bar	G1"	936701Q
15CN210QEVT1KG164	F315CN2R10QETW350C2C219	80	15CN	Length 2	10	Fluoroelastomer	Electrical	3.5 bar	G1"	936704Q
15CN210QEV3M3KG164	F315CN2R10QEM250C2C219	80	15CN	Length 2	10	Fluoroelastomer	Visual	3.5 bar	G1"	936704Q
15CN220QEVT1KG164	F315CN2R20QETW350C2C219	100	15CN	Length 2	20	Fluoroelastomer	Electrical	3.5 bar	G1"	936705Q
15CN220QEV3M3KG164	F315CN2R20QEM250C2C219	100	15CN	Length 2	20	Fluoroelastomer	Visual	3.5 bar	G1"	936705Q
40CN105QEVT1KG244	F340CN1R05QETW350E2E219	120	40CN	Length 1	5	Fluoroelastomer	Electrical	3.5 bar	G1½"	936707Q
40CN105QEV3M3KG244	F340CN1R05QEM250E2E219	120	40CN	Length 1	5	Fluoroelastomer	Visual	3.5 bar	G1½"	936707Q
40CN110QEVT1KG244	F340CN1R10QETW350E2E219	180	40CN	Length 1	10	Fluoroelastomer	Electrical	3.5 bar	G1½"	936708Q
40CN110QEV3M3KG244	F340CN1R10QEM250E2E219	180	40CN	Length 1	10	Fluoroelastomer	Visual	3.5 bar	G1½"	936708Q
40CN120QEVT1KG244	F340CN1R20QETW350E2E219	260	40CN	Length 1	20	Fluoroelastomer	Electrical	3.5 bar	G1½"	936709Q
40CN120QEV3M3KG244	F340CN1R20QEM250E2E219	260	40CN	Length 1	20	Fluoroelastomer	Visual	3.5 bar	G1½"	936709Q
40CN205QEVT1KG244	F340CN2R05QETW350E2E219	200	40CN	Length 2	5	Fluoroelastomer	Electrical	3.5 bar	G1½"	936711Q
40CN205QEV3M3KG244	F340CN2R05QEM250E2E219	200	40CN	Length 2	5	Fluoroelastomer	Visual	3.5 bar	G1½"	936711Q
40CN210QEVT1KG244	F340CN2R10QETW350E2E219	280	40CN	Length 2	10	Fluoroelastomer	Electrical	3.5 bar	G1½"	936601Q
40CN210QEV3M3KG244	F340CN2R10QEM250E2E219	280	40CN	Length 2	10	Fluoroelastomer	Visual	3.5 bar	G1½"	936601Q
40CN220QEVT1KG244	F340CN2R20QETW350E2E219	320	40CN	Length 2	20	Fluoroelastomer	Electrical	3.5 bar	G1½"	936712Q
40CN220QEV3M3KG244	F340CN2R20QEM250E2E219	320	40CN	Length 2	20	Fluoroelastomer	Visual	3.5 bar	G1½"	936712Q
80CN110QEVT1KG324	F380CN1R10QETW350F2F219	370	80CN	Length 1	10	Fluoroelastomer	Electrical	3.5 bar	G2"	936602Q
80CN110QEV3M3KG324	F380CN1R10QEM250F2F219	370	80CN	Length 1	10	Fluoroelastomer	Visual	3.5 bar	G2"	936602Q
80CN120QEVT1KG324	F380CN1R20QETW350F2F219	420	80CN	Length 1	20	Fluoroelastomer	Electrical	3.5 bar	G2"	936715Q
80CN120QEV3M3KG324	F380CN1R20QEM250F2F219	420	80CN	Length 1	20	Fluoroelastomer	Visual	3.5 bar	G2"	936715Q
80CN210QEVT1KG324	F380CN2R10QETW350F2F219	530	80CN	Length 2	10	Fluoroelastomer	Electrical	3.5 bar	G2"	936718Q
80CN210QEV3M3KG324	F380CN2R10QEM250F2F219	530	80CN	Length 2	10	Fluoroelastomer	Visual	3.5 bar	G2"	936718Q
80CN220QEVT1KG324	F380CN2R20QETW350F2F219	600	80CN	Length 2	20	Fluoroelastomer	Electrical	3.5 bar	G2"	936719Q
80CN220QEV3M3KG324	F380CN2R20QEM250F2F219	600	80CN	Length 2	20	Fluoroelastomer	Visual	3.5 bar	G2"	936719Q

Note: Filter assemblies ordered from the product configurator on next page are on extended lead times. Where possible, please make your selection from the table above.

Medium Pressure Filters

15/40/80CN Series

Ordering Information (cont.)

Product Configurator

Box 1 40CN	Box 2 2	Box 3 10QE	Box 4 V	Box 5 M3	Box 6 K	Box 7 G24	Box 8 4
----------------------	-------------------	----------------------	-------------------	--------------------	-------------------	---------------------	-------------------

Code	
Model	Code
Small size MP filter, T-port	15CN
Medium size MP filter, T-port	40CN
Large size MP filter, T-port	80CN

Filter type	
Length	Code
Length 1	1
Length 2	2

Highlights Key (Denotes part number availability)

123	Item is standard
123	Item is standard green option
123	Item is semi standard
123	Item is non standard

Note: Standard items are in stock, semi standard items are available within four weeks

Degree of filtration				
Element media	Glass fibre			
	Media code			
Ecoglass III element	02QE	05QE	10QE	20QE

Note: When using Ecoglass III elements a bowl with reusable Eco-adaptor is required. Filter assemblies with Microglass III elements are available by request

Seal type	
Seal material	Code
Fluoroelastomer	V
Nitrile	B

Indicator	
	Code
No indicator port	N
Visual indicator	M3
Electrical indicator	T1
Plugged with steel plug	P
Electronic 4 LED, PNP, N.O.	F1
Electronic 4 LED, NPN, N.O.	F2
Electronic 4 LED, PNP, N.C.	F3
Electronic 4 LED, NPN, N.C.	F4

Bypass valve		
Bypass valve	Indicator	Code
1.7 bar	1.2 bar	G
3.5 bar	2.5 bar	K

When filter includes a bypass valve but not an indicator, code denotes bypass setting.

Filter connection	
Ports	Code
15CN: Thread G ³ / ₄	G12
Thread G1	G16
Thread SAE 12	S12
Thread SAE 16	S16
Thread M27, ISO6149	M27
40CN: Thread G1 ¹ / ₂	G20
Thread G1 ¹ / ₂	G24
Thread SAE 16	S16
Thread SAE 24	S24
Thread M33, ISO6149	M33
80CN: Thread G1 ¹ / ₂	G24
Thread G2	G32
Thread SAE 24	S24
Thread SAE 32	S32
Thread M42, ISO6149	M42
Thread M48, ISO6149	M48
SAE flange 2" 3000-M	R32

Options	
Options	Code
Standard drain port on bowl	4

Ecoglass III elements (Fluoroelastomer seals)				
Model	02QE	05QE	10QE	20QE
15CN-1	936698Q	936699Q	936700Q	936701Q
15CN-2	936702Q	936703Q	936704Q	936705Q
40CN-1	936706Q	936707Q	936708Q	936709Q
40CN-2	936710Q	936711Q	936601Q	936712Q
80CN-1	936713Q	936714Q	936602Q	936715Q
80CN-2	936716Q	936717Q	936718Q	936719Q

Seal kits		
Model	Nitrile	Fluoroelastomer*
15CN	S04449	S04450
40CN	S04447	S04448
80CN	S04458	S04459

Replacement element part numbers for conventional assemblies

Conversion bowl assembly <small>(to retrofit existing CN filter housings to use coreless elements)</small>	
936758	15CN-1 coreless element bowl assembly
936759	15CN-2 coreless element bowl assembly
936760	40CN-1 coreless element bowl assembly
936761	40CN-2 coreless element bowl assembly
936763	80CN-1 coreless element bowl assembly
936764	80CN-2 coreless element bowl assembly

Elements with nitrile seals				
Model	02Q	05Q	10Q	20Q
15CN-1	928935Q	G04041Q	928934Q	930367Q
15CN-2	928953Q	G04169Q	928952Q	930368Q
40CN-1	926696Q	G04048Q	926835Q	930099Q
40CN-2	926697Q	G04167Q	926837Q	930118Q
80CN-1	932656Q	932657Q	932658Q	929899Q
80CN-2	932662Q	932663Q	932664Q	929923Q

Elements with Fluoroelastomer seals				
Model	02Q	05Q	10Q	20Q
15CN-1	932610Q	G04189Q	932612Q	930369Q
15CN-2	932616Q	G04190Q	932618Q	930370Q
40CN-1	926716Q	G04191Q	926836Q	930100Q
40CN-2	926717Q	G04192Q	926838Q	930119Q
80CN-1	932659Q	932660Q	932661Q	929903Q
80CN-2	932665Q	932666Q	932667Q	929927Q

Degree of filtration						Code
Average filtration beta ratio β (ISO 16889) / particle size μm [c]						
$\beta(x)=2$	$\beta(x)=10$	$\beta(x)=75$	$\beta(x)=100$	$\beta(x)=200$	$\beta(x)=1000$	Metal free Ecoglass III
% efficiency, based on the above beta ratio (βx)						
50.0%	90.0%	98.7%	99.0%	99.5%	99.9%	
N/A	N/A	N/A	N/A	N/A	4.5	05QE
N/A	N/A	4.5	5	6	7	
N/A	6	8.5	9	10	12	10QE
6	11	17	18	20	22	
						20QE

Nominal flow (l/min) for filter assembly at viscosity 30cSt				
Housing, port size	02QE	05QE	10QE	20QE
15CN-1, G1	10	30	50	80
15CN-2, G1	30	70	80	100
40CN-1, G1 ¹ / ₂	60	120	180	260
40CN-2, G1 ¹ / ₂	80	200	280	320
80CN-1, G2	150	300	370	420
80CN-2, G2	180	420	530	600

* Fluoroelastomers are available under various registered trademarks, including Viton (a registered trademark of DuPont) and Fluorel (a registered trademark of 3M)

Please note the bolded options reflect standard options with a reduced lead-time of (4) weeks or less. Consult Parker Filtration on all other lead-time options.





Medium Pressure Filters

45M/45M Eco Series

MAX 260 l/min - 40 bar

FEATURING
EC GLASS III



Medium Pressure Filters

45M/45M Eco Series

Features & Benefits

Features	Advantages	Benefits
Cast iron head, steel bowl	Can be used in applications where aluminium is not allowed	Approved for engine rooms and mines
	Rugged construction	Reliable filtration in all conditions
Reinforced Microglass III replacement elements	Multi-layered design produced high capacity and efficiency	Great performance value
	Wire support reduces pleat bunching, keeps performance consistent	Reliable performance throughout element life
Visual, electrical or electronic indicators available	Check element condition at glance	Reduces downtime, maximises element life
	Right style for the application	Optimise element life, prevent bypassing
Test points in the filter head	Pressure measurement and Δp possible	Matches your system electrical connections
Coreless Ecoglass III replacement elements	No metal content in element	Quick testing and maintenance
	Reduced overall weight of 50%	Environmentally friendly disposal by incineration
	Easy compaction of used elements	Lower element replacement costs
	Eco adaptors available	Lower disposal costs
		Retrofit coreless design to housings already installed

Typical Applications

- Industrial power units
- Mobile construction equipment
- Forestry equipment

The Parker Filtration 45M/45 Eco Series Medium Pressure Filters.

The 45M/45 Eco Series of medium pressure filters offer an ideal solution to the problem of protecting system components at lower pressures.

These filters are a realistic, high quality alternative to low specification spin-on filters. The 45M/45 Eco Series offers high dirt holding capacity, 40 bar capability and rapid element replacement.



Specification

Pressure ratings:

Maximum allowable operating pressure 40 bar.
Filter housing pressure pulse fatigue tested: 10^6 pulses 0-40 bar.

Connections:

Threads G1, G1 $\frac{1}{4}$ (ISO 228/1) or flange SAE 1 $\frac{1}{2}$ " 3000-M.

Filter housing:

Head material cast iron (GSI).
Bowl material steel.

Seal material:

Nitrile or Fluoroelastomer.

Operating temperature range:

-20° to +100°C

Bypass valve:

Opening pressure 3.5 bar.

Filter element:

Degree of filtration:

Determined by Multipass-test according to ISO 16889.

Flow fatigue characteristics:

Filter media is supported so that the optimal fatigue life is achieved (ISO 3724).

Microglass III:

Supported with epoxy coated metal wire mesh, end cap material reinforced composite and metal inner core.
Collapse rating 20 bar (ISO 2941).

Ecoglass III:

Supported with plastic net, end cap material reinforced composite. No metal parts. Collapse rating 10 bar (ISO 2941).
Filter element can only be used together with reusable FEA Eco-adapter. Note: Ecoglass III contributes to ISO 14001 quality.

Indicator options:

Indicating differential pressure: 2.5 ± 0.3 bar.

- visual M3.
 - electrical T1.
 - electronic F1(PNP).
 - electronic F2(NPN).
- For indicator details see catalogue section 6.

Fluid compatibility:

Suitable for use with mineral and vegetable oils, and some synthetic oils. For other fluids, please consult Parker Filtration.

Installation Details

Type	A	B	C	Weight (kg)	D
Length 1	116 (4.57)	237 (9.33)	192 (7.56)	5.9	G1, G1 $\frac{1}{4}$, G1 $\frac{1}{2}$, Flange SAE 1 $\frac{1}{2}$ " 3000-M
Length 2	208 (8.20)	330 (13.00)	285 (11.22)	6.2	
Length 3	329 (13.00)	450 (17.72)	405 (15.94)	6.6	
Length 4	428 (16.85)	550 (21.65)	505 (19.90)	7.0	

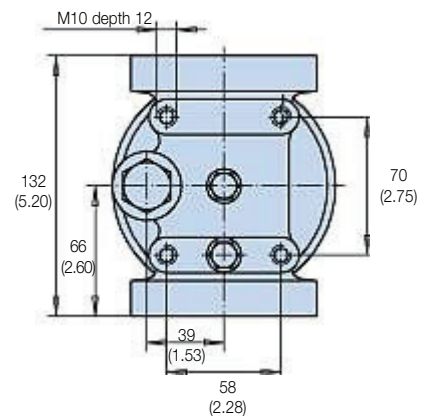
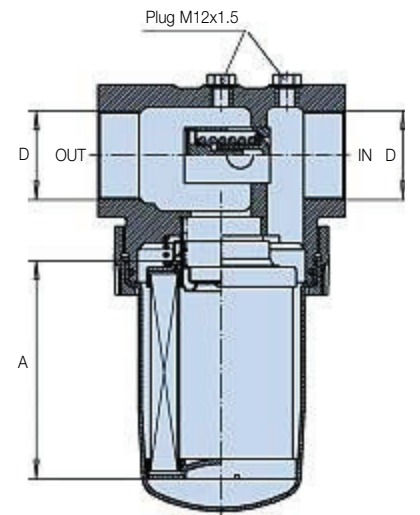
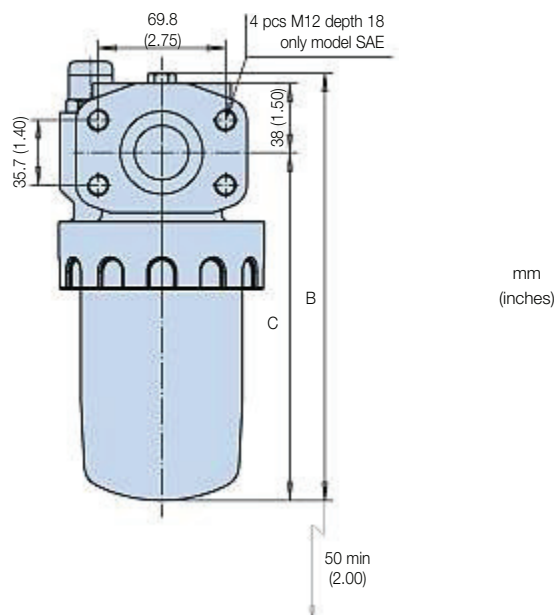

45M/45M Eco Series

Pressure Drop Curves

The recommended level of the initial pressure drop is max 1.0 bar.

If the medium used has a viscosity different from 30 cSt, pressure drop over the filter can be estimated as follows:

The total $\Delta p = \Delta p_{\text{housing}} + (\text{element } \Delta p_e \times \text{working viscosity}/30)$.

45M Series Empty Housing

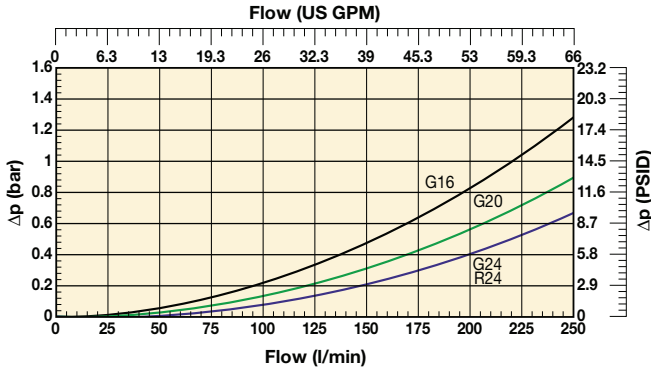

45M-1 Element with Microglass III

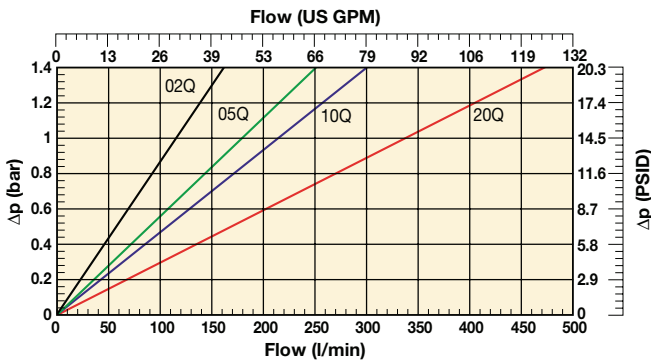

45M-2 Element with Microglass III

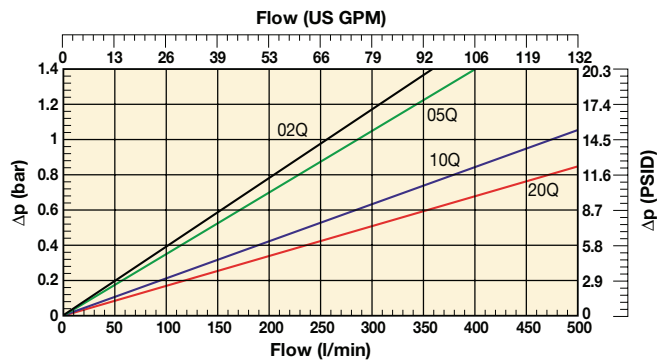

45M-3 Element with Microglass III

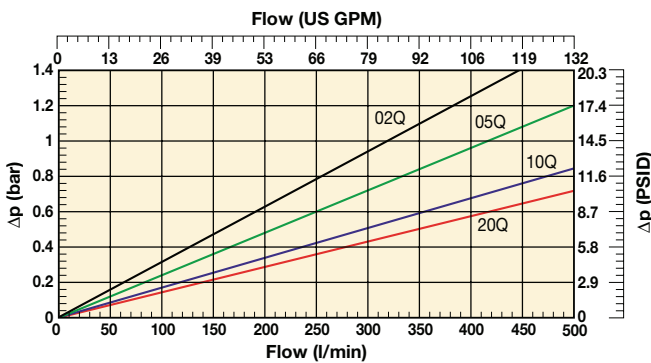

45M-4 Element with Microglass III

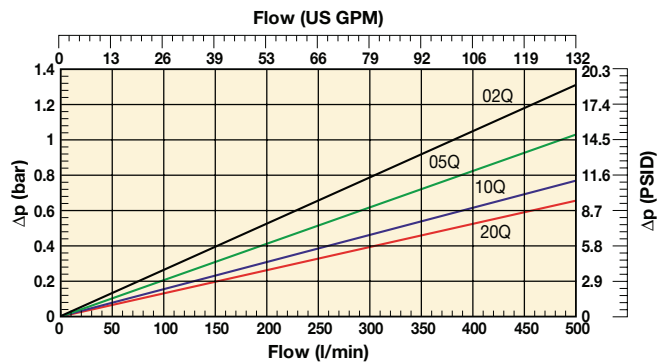

45M-1 Element with Ecoglass III

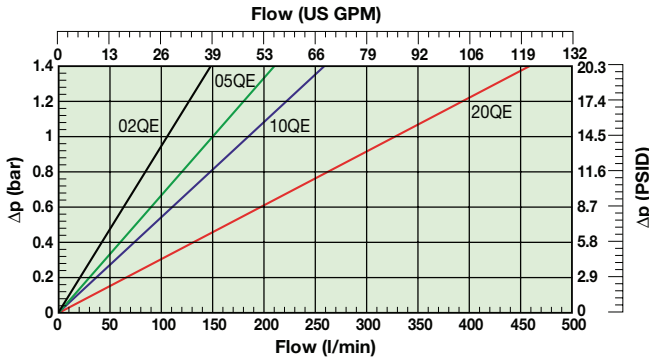

45M-2 Element with Ecoglass III

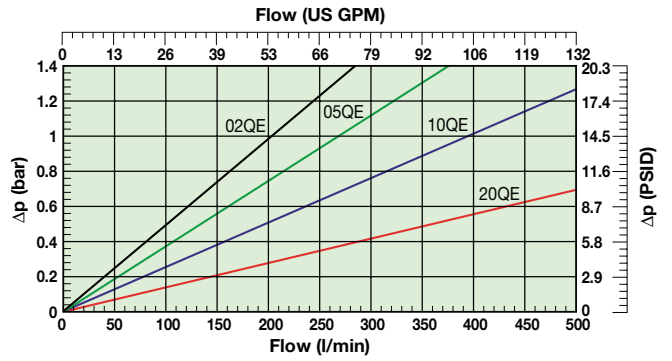

45M-3 Element with Ecoglass III

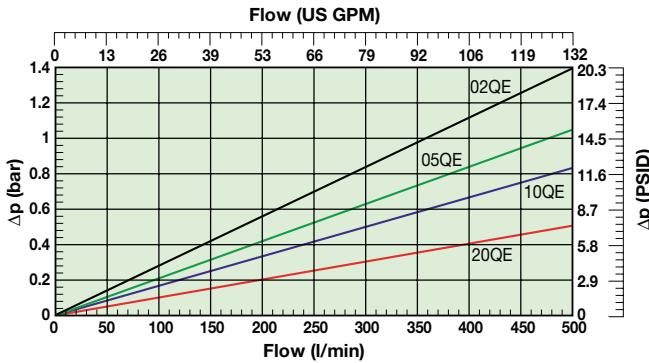

45M-4 Elements with Ecoglass III

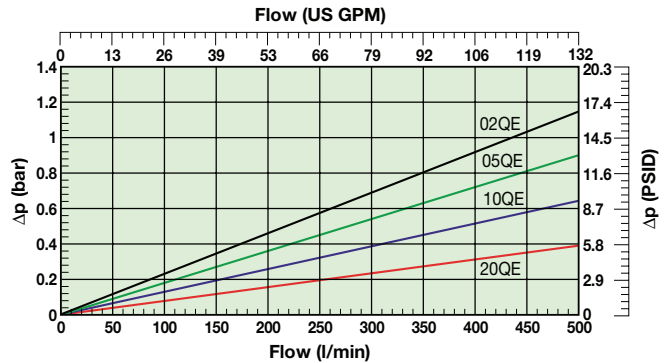

Ordering Information

Standard products table

Product numbers	Supersedes	Flow (l/min)	Model number	Element length	Media rating (μ)	Seals	Indicator	Bypass settings	Ports	Replacement elements	Supersedes
45M110QBPKG161	FF1145.Q010.BS35.GT16	140	45M	Length 1	10	Nitrile	Plugged	3.5 bar	G1"	938962Q	FC7005.Q010.BK
45M120QBPKG161	FF1145.Q020.BS35.GT16	160	45M	Length 1	20	Nitrile	Plugged	3.5 bar	G1"	938963Q	FC7005.Q020.BK
45M110QEBPKG161	FF1145.QE10.BS35.GT16	140	45M	Length 1	10	Nitrile	Plugged	3.5 bar	G1"	938978Q	FC7005.QE10.BK
45M120QEBPKG161	FF1145.QE20.BS35.GT16	160	45M	Length 1	20	Nitrile	Plugged	3.5 bar	G1"	938979Q	FC7005.QE20.BK
45M210QBPKG201	FF1146.Q010.BS35.GT20	200	45M	Length 2	10	Nitrile	Plugged	3.5 bar	G1½"	938966Q	FC7006.Q010.BK
45M220QBPKG201	FF1146.Q020.BS35.GT20	220	45M	Length 2	20	Nitrile	Plugged	3.5 bar	G1½"	938967Q	FC7006.Q020.BK
45M210QEBPKG201	FF1146.QE10.BS35.GT20	200	45M	Length 2	10	Nitrile	Plugged	3.5 bar	G1½"	938982Q	FC7006.QE10.BK
45M220QEBPKG201	FF1146.QE20.BS35.GT20	220	45M	Length 2	20	Nitrile	Plugged	3.5 bar	G1½"	938983Q	FC7006.QE20.BK
45M310QBPKG241	FF1147.Q010.BS35.GT24	230	45M	Length 3	10	Nitrile	Plugged	3.5 bar	G1½"	938970Q	FC7007.Q010.BK
45M320QBPKG241	FF1147.Q020.BS35.GT24	250	45M	Length 3	20	Nitrile	Plugged	3.5 bar	G1½"	938971Q	FC7007.Q020.BK
45M310QEBPKG241	FF1147.QE10.BS35.GT24	230	45M	Length 3	10	Nitrile	Plugged	3.5 bar	G1½"	938986Q	FC7007.QE10.BK
45M320QEBPKG241	FF1147.QE20.BS35.GT24	250	45M	Length 3	20	Nitrile	Plugged	3.5 bar	G1½"	938987Q	FC7007.QE20.BK

Note: Filter assemblies ordered from the product configurator below are on extended lead times. Where possible, please make your selection from the table above.

Note 1: Part numbers featured with bold highlighted codes will ensure a 'standard' product selection.

Medium Pressure Filters

45M/45M Eco Series

Ordering Information (cont.)

Product configurator

Box 1	Box 2	Box 3	Box 4	Box 5	Box 6	Box 7	Box 8
45M	2	10Q	B	M3	K	G20	1

Box 1

Code	
Model	Code
Medium pressure filter, T-port	45M

Highlights Key (Denotes part number availability)

123	Item is standard
123	Item is standard green option
123	Item is semi standard
123	Item is non standard

Note: Standard items are in stock, semi standard items are available within four weeks

Box 2

Filter type	
Length	Code
Length 1	1
Length 2	2
Length 3	3
Length 4	4

Box 3

Degree of filtration				
Element media	Glass fibre			
	Media code			
Microglass III element	02Q	05Q	10Q	20Q
Ecoglass III element	02QE	05QE	10QE	20QE

Note: When using Ecoglass III elements a bowl with reusable Eco-adaptor is required.

Box 4

Seal type	
Seal material	Code
Nitrile	B
Fluoroelastomer	V

Box 5

Indicator	
	Code
Plugged with steel plug	P
Visual indicator	M3
Electrical indicator	T1
Electronic 4 LED, PNP, N.O.	F1
Electronic 4 LED, NPN, N.O.	F2
Electronic 4 LED, PNP, N.C.	F3
Electronic 4 LED, NPN, N.C.	F4

Box 6

Bypass valve		
Bypass valve	Indicator	Code
3.5 bar	2.5 bar	K
No bypass*	7.0 bar	N
No bypass*	No indicator (P)	X

+ Box 8: code 2
+ Box 8: code 2

* High collapse element must be used if MAOP is higher than element collapse pressure.
When filter includes a bypass valve but not an indicator, code denotes bypass setting.

Box 7

Filter connection					
Connections	Code	Length 1	Length 2	Length 3	Length 4
Thread G 1	G16	S	S	S	x
Thread G 1 1/4	G20	S	S	S	S
Thread G 1 1/2	G24	x	S	S	S
SAE flange 1 1/2" 3000-M	R24	x	x	x	x

Availability: **S** = standard option
x = non-standard, ask for availability

Box 8

Options	
Options	Code
Standard	1
No bypass	2

Replacement elements with nitrile seals				
Media	Length 1	Length 2	Length 3	Length 4
02Q	938960Q	938964Q	938968Q	938972Q
05Q	938961Q	938965Q	938969Q	938973Q
10Q	938962Q	938966Q	938970Q	938974Q
20Q	938963Q	938967Q	938971Q	938975Q
02QE	938976Q	938980Q	938984Q	938988Q
05QE	938977Q	938981Q	938985Q	938989Q
10QE	938978Q	938982Q	938986Q	938990Q
20QE	938979Q	938983Q	938987Q	938991Q

Nominal flow (l/min) at viscosity 30 cSt - connection size				
Filter length	Media	G16	G20	G24 & R24
Length 1	02Q/02QE	80	80	80
	05Q/05QE	120	120	120
	10Q/10QE	140	150	150
	20Q/20QE	160	180	200
Length 2	02Q/02QE	130	150	170
	05Q/05QE	150	170	190
	10Q/10QE	170	200	230
	20Q/20QE	190	220	250
Length 3	02Q/02QE	150	170	190
	05Q/05QE	170	190	210
	10Q/10QE	190	210	230
	20Q/20QE	200	230	250
Length 4	02Q/02QE	170	190	210
	05Q/05QE	180	210	230
	10Q/10QE	190	220	240
	20Q/20QE	200	230	260

Degree of filtration						Code	
Average filtration beta ratio β (ISO 16889) / particle size μm [c]							
$\beta_x(c)=2$	$\beta_x(c)=10$	$\beta_x(c)=75$	$\beta_x(c)=100$	$\beta_x(c)=200$	$\beta_x(c)=1000$		
% efficiency, based on the above beta ratio (β_x)							
50.0%	90.0%	98.7%	99.0%	99.5%	99.9%	Disposable	Metal free
N/A	N/A	N/A	N/A	N/A	4.5	02Q	02QE
N/A	N/A	4.5	5	6	7	05Q	05QE
N/A	6	8.5	9	10	12	10Q	10QE
6	11	17	18	20	22	20Q	20QE



Medium Pressure Filters

130 Eco Series

MAX 1000 l/min - 30 bar

FEATURING
EC GLASS III



Medium Pressure Filters

130 Eco Series

Features & Benefits

Features	Advantages	Benefits
Modular filter system	Sizing and performance can be optimised	Best filter for every lube application
Duplex type systems with selecting valve	Element change during operation	Continuous filtration
Bypass assembly in the filter cover	Sediment and other particles at the bottom are away from the flow entering the system	No contamination passing into the system if filter in bypass
Large filtration area	High dirt holding capacity	Long element life
Air bleed valve	Easy air removal after element change	Protects bearings and other sensitive components
Two indicator locations, visual indicator as standard	Easy to detect when element replacement needed	Reliable filtration
Coreless Ecoglass III replacement elements	No metal content in element	Environmentally friendly disposal by incineration
	Reduced overall weight of 50%	
	Easy compaction of used elements	Lower disposal costs
	Conversion kits available: new bowl with permanent core	Retrofit coreless design to housings already installed

Typical Applications

- Paper production plants
- Steel mills
- Aluminium mills
- Industrial power packs
- Lubrication systems
- Power generation

The Parker Filtration 130 Eco Series Medium Pressure Filters.

These high flow return filters are ideal for industrial applications on hydraulic or lubrication systems with pressures up to 30 bar and flows up to 1000 l/min in single units. Multiple filter systems with pressures up to 16 bar and flows up to 1400 l/min.

The ability to bank multiple filters together in a “duplex” format enables continuous filtration during element changes.



Specification

Pressure ratings:

Maximum allowable operating pressure:

Single filters 30 bar.

Filter systems 16 bar.

Filter housing pressure pulse fatigue tested: 10⁶ pulses 0-25 bar.

Construction:

Eco-element does not include any metal parts and is supported by Eco-adaptor. Conventional elements can be used without removing the Eco-adaptor.

Connections:

Single unit connections:

Flanges SAE 2" 3000-M, SAE 2 1/2" 3000-M or with adaptor threads G1 1/2 or G2.

Dual unit connections:

Flanges SAE 3" 3000-M or with adaptor threads G1 1/2 or G2.

Parallel unit and filter system assembly connections:

DN80/PN16 or DN100/PN16. Assembly of two, four six or eight filters to the same system by using L-bore valve assembly (only one side in use).

Filter housing:

Material aluminium.

Seal material:

Nitrile or Fluoroelastomer.

Operating temperature range:

-20°C to +100°C.

Bypass valve:

Opening pressure 3.5 bar.

Filter element:

Degree of filtration:

Determined by Multipass-test according to ISO 16889.

Flow fatigue characteristics:

Filter media is supported so that the optimal fatigue life is achieved (ISO 3724).

Ecoglass III:

Supported with plastic net, end cap material reinforced composite. No metal parts. Collapse rating 10 bar (ISO 2941).

Filter element can only be used together with reusable FEA Eco-adaptor. Note: Ecoglass III contributes to ISO 14001 quality.

Also available with Microglass III elements. Contact Parker Filtration for details.

Visual indicator:

Includes M3, full part number FMUM3KVMU12H as standard.

Optional Indicators (mounted to lower indicator port):

- electrical T1.
- electronic F1 (PNP).
- electronic F2 (NPN).

For indicator details see catalogue section 6.

Fluid compatibility:

Suitable for use with mineral and vegetable oils, and some synthetic oils. For other fluids, please consult Parker Filtration.

Installation Details

Single Assemblies 130M

Connection options

Body flange	SAE 2" 3000-M
	SAE 2 1/2" 3000-M
Adaptor flange	G1 1/2
	G2
	SAE 3" 3000-M (90° elbow)

Weights (kg)	Length 2	Length 3
Single	24.5	32.5
Dual D2	70.2	86.2
Parallel P2	75.2	91.2
System S2	111.0	127.0
System S9	204.0	236.0
System S6	261.2	309.2
System S8	341.4	705.4

Dimensions in mm

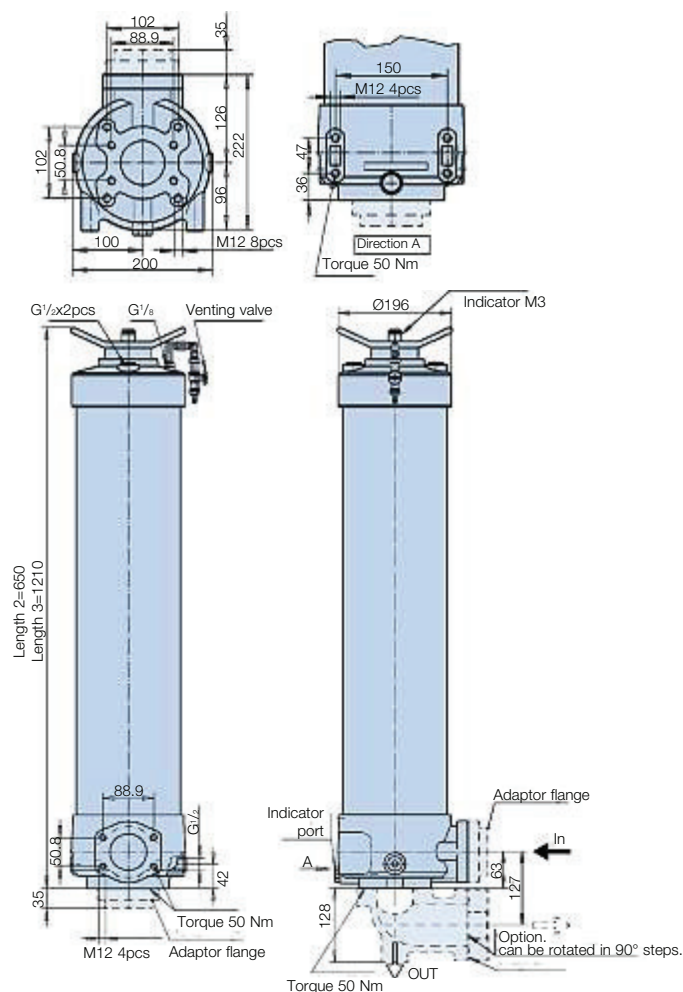

Medium Pressure Filters

130 Eco Series

Dual System 130D

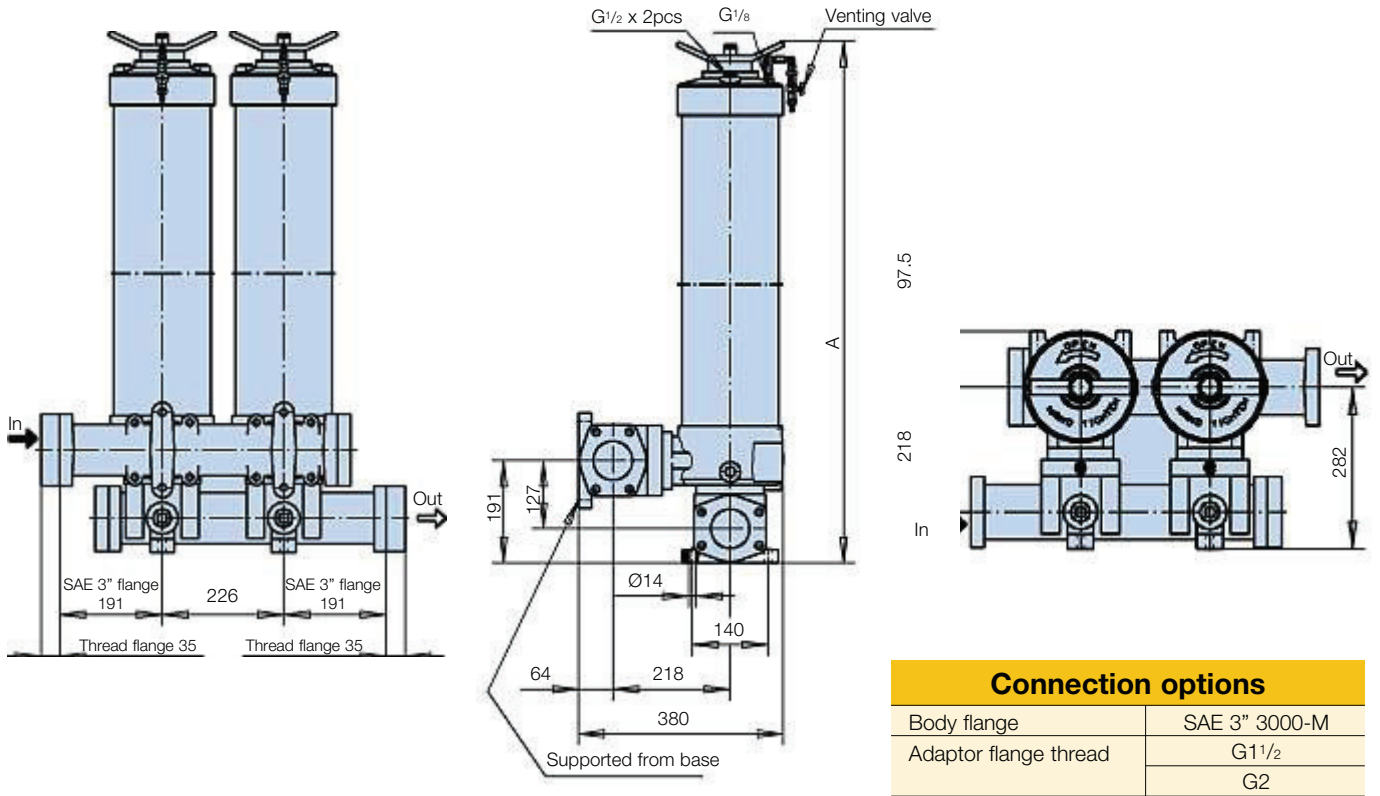

Connection options	
Body flange	SAE 3" 3000-M
Adaptor flange thread	G1½
	G2

Parallel System 130N

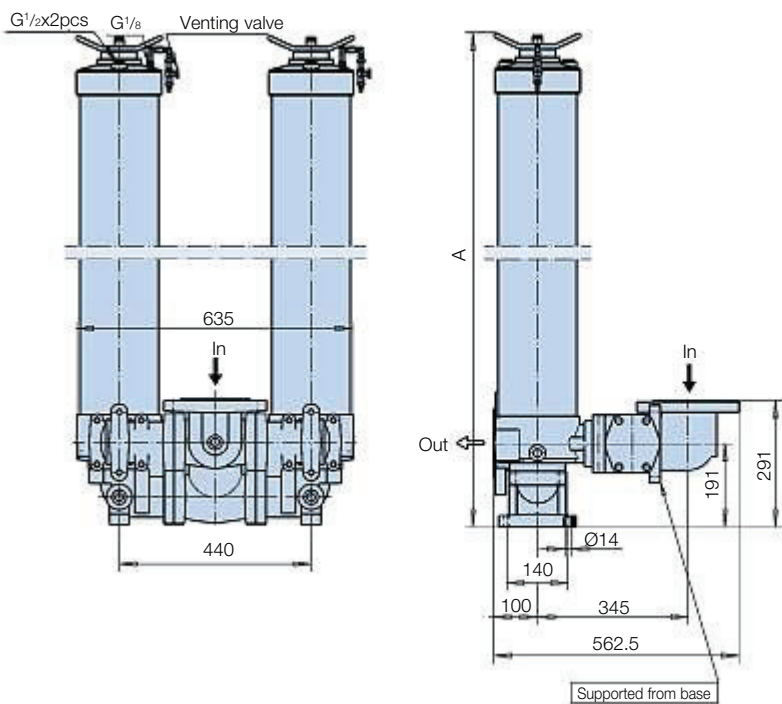

Type	A
Length 2	780
Length 3	1340

Dimensions in mm

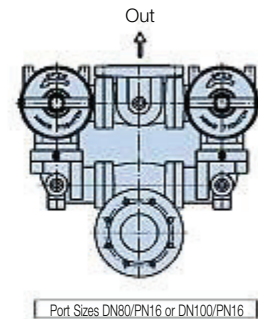

130S System 1+1 units

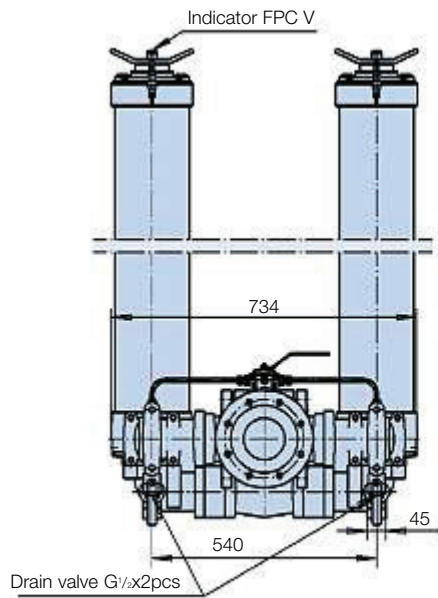

130S System 2+2 units

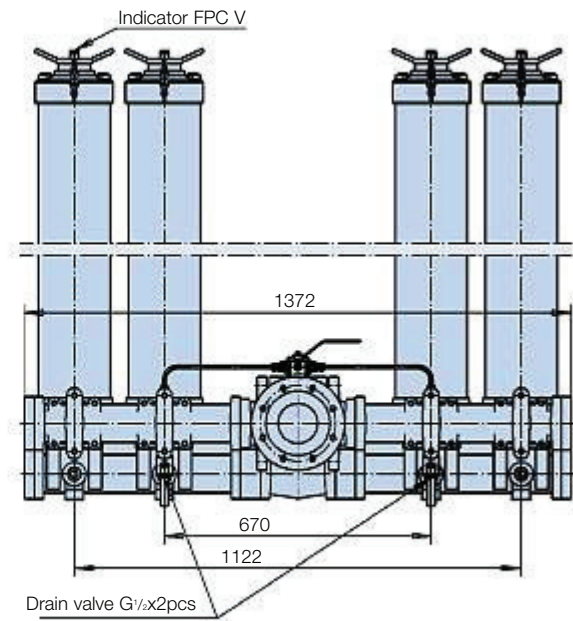

130S System 3+3 units

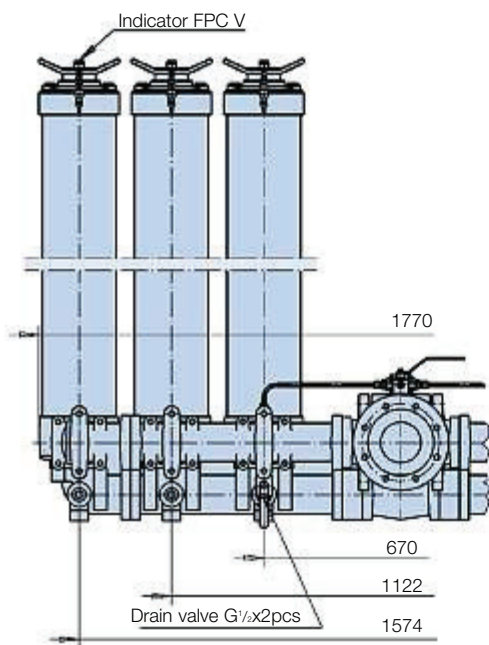

130S System 4+4 units

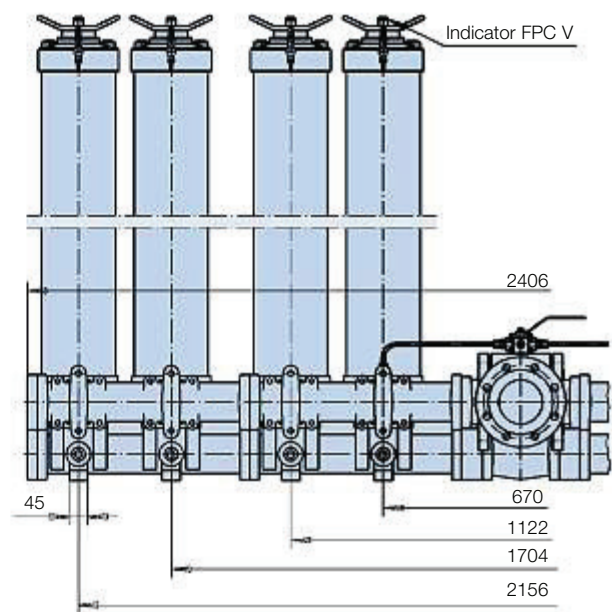

130 Eco Series

Valve Assembly Connection - T-Model

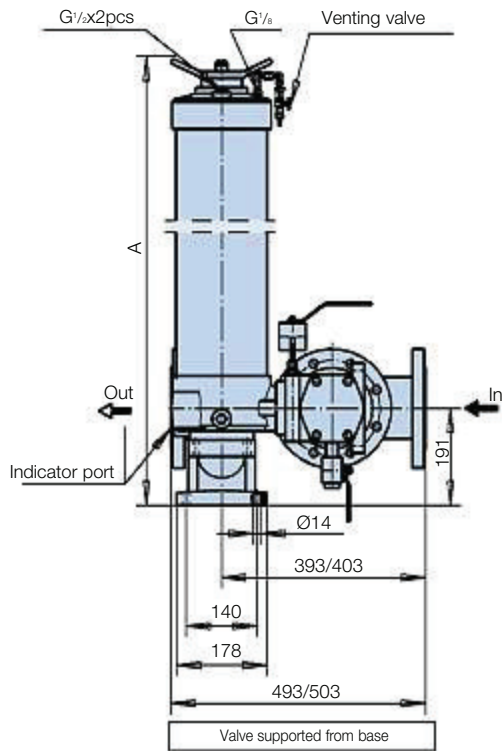

Type	A
Length 2	780
Length 3	1340

Dimensions in mm

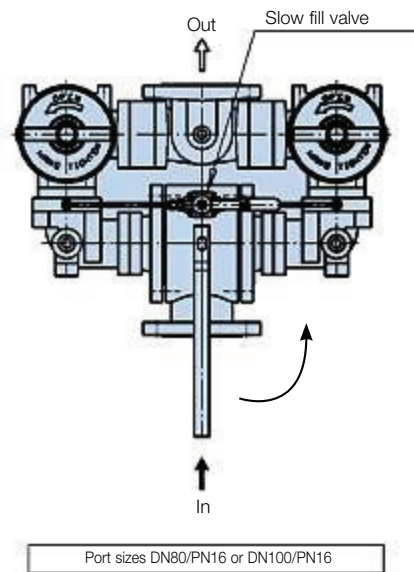

L-Model

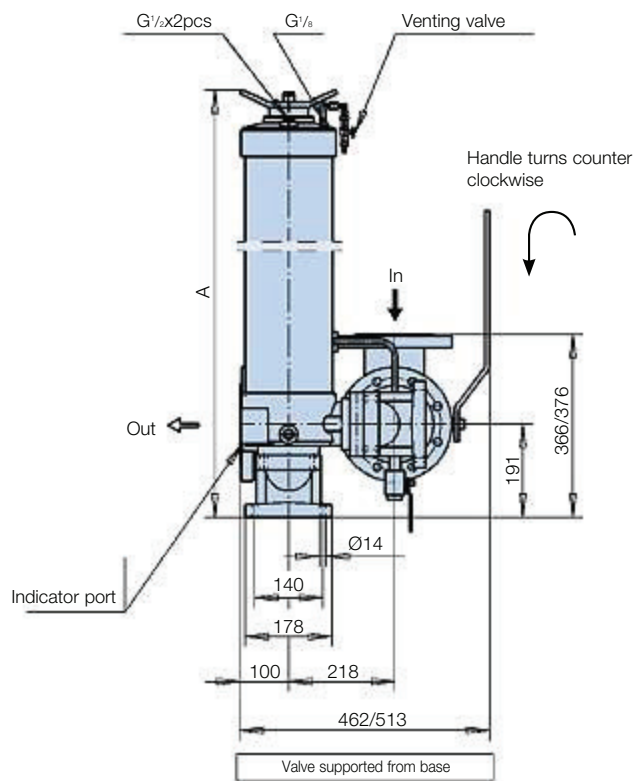

C-Model

